

2021
RIMS



ALEXRIMS





We began in 1992 with the goal of building the highest quality alloy bicycle rims. Since our humble beginning in 1992, Alex Global Technology has developed into the global leader in rim and wheel technology, design, materials and manufacturing.

Here at Alex Global Technology we design and build bicycle specific products for the way YOU ride.

We are an engineering company at heart with a true passion for cycling. We understand cycling because we are cyclists. We have the drive, knowledge and skill to make the best products on the market. We control our manufacturing process 100%. From Bauxite to finished product it never leaves our hands. We never compromise quality or performance and as a result, produce some of the strongest, lightest and best functioning wheels and rims on the market.

We've partnered with a great team of professional athletes all over the world, in every category be it Road, DH, XC, Enduro, Slopestyle or BMX. They test, evaluate and change our products before they are released into the market. They all agree that Alexrims is creating industry leading wheels and rims that promote success in all disciplines of riding and racing.

When you are ready to take your riding to the next level in performance and quality think ALEXRIMS. We make rims...

FOR THE WAY YOU RIDE.



Dr. Alex Chen



CONTENTS

RACING/CYCLOCROSS PAGE 10

RA30	AT505 *NEW*	ATD500 *NEW*
R450	GV24P	GD24P
AT470	ATD470	GX26P *NEW*

MTB/TREKKING PAGE 12

DP30 *NEW*	MD19	EV23
DP27	G6000	DA16
DP25	X2200	X1700
DP23	X2000	ACE17
DP21	X2800	DM18
XD-ELITE	XD2800	DC19
	DH19	

PLUS PAGE 16

MD35

ENDURO/BMX PAGE 18DM24
MUS30**SINGLE WALL** PAGE 19

Y303	ZUMA3.0
C303	AP18
C1000	Z1000
ZUMA1.0	C2000 *NEW*

E-BIKE/RIM PAGE 22

DP23	DH19
DM24	DM18
EV23	

TUBELESS READY SYSTEM

(TRS)

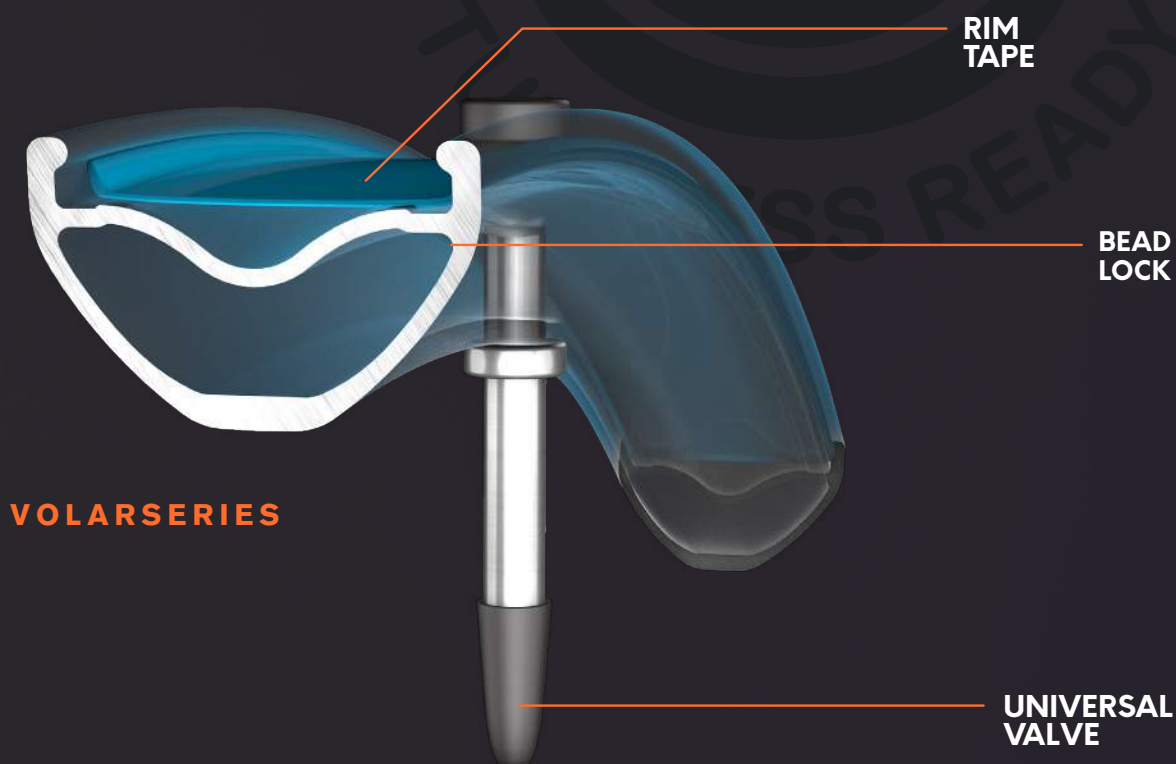

VOLAR SERIES



1 Install blue rim tape evenly across the inside of the rim while covering the spoke holes up to the sides.



2 Put valve stem through valve hole. Push firmly on the rubber side of the valves as you tighten the valve nut with your hands.

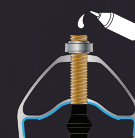

3 Remove the valve core and add sealant to the tire through the valve. Shake the wheel to coat the inside of the tire and replace valve core.

3D DRILLING

Alexrims offers further customization for a variety of applications including our 3D drilling technology. 3D drilling makes our most popular rim profiles compatible with large flange hubs as well as e-bike hubs.



DM18

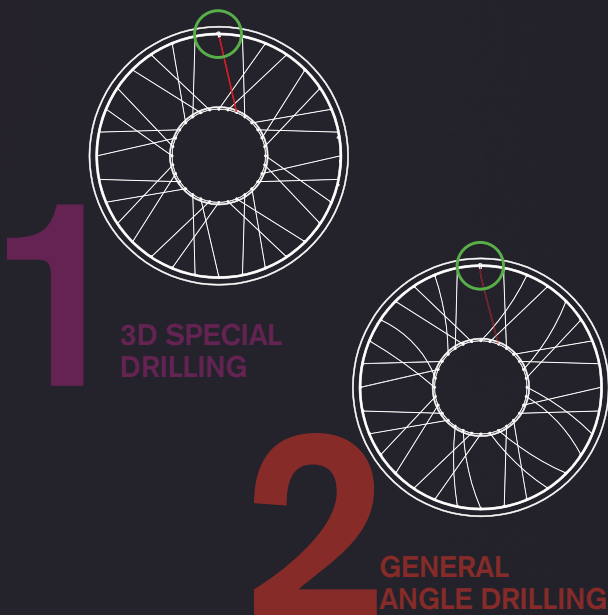
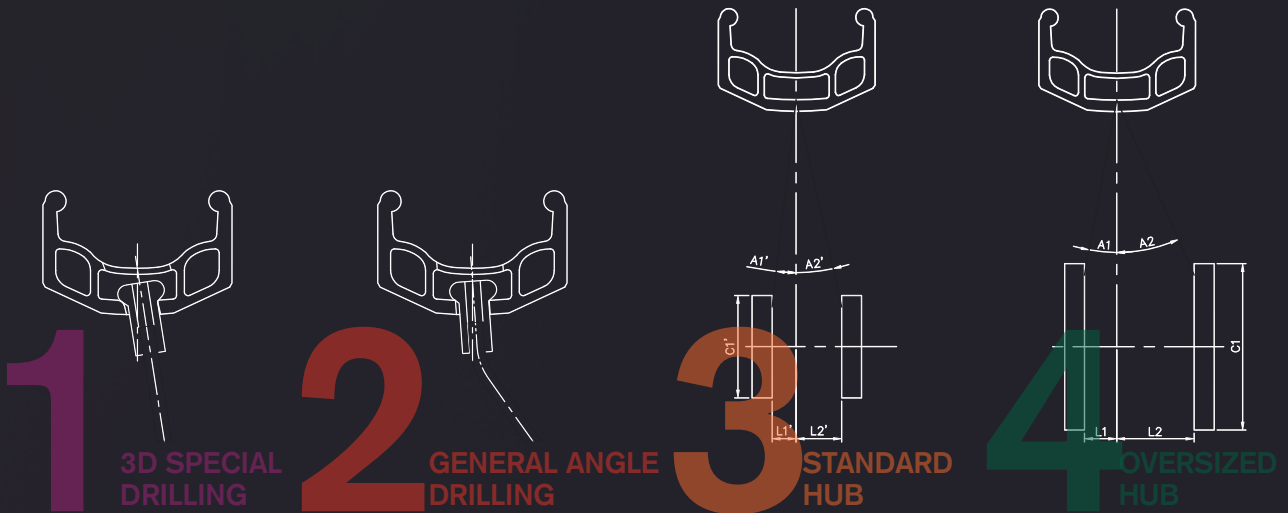

- ▶ E-bikes have grown into a major segment in recent years
- ▶ Zero need for compromise with technologies from Alexrims
- ▶ Select from a wider variety of rim profiles as 3D drilling can be applied to any of them. Alexrims expands your choices while offering leading technology that enhances performance.

SIDEWALL TECHNOLOGY

**INDICATOR (PATENTED)**

The Indicator is an ALEXRIMS patented design that incorporates a 0.3mm deep line in the sidewall. As the rim becomes thinner from use the color indicator becomes lighter alerting the user that it is time to replace the rim.

RIM TECHNOLOGY

**ANTI SNAKE BITE**

ALEXRIMS developed the ASB design to minimize pinch flats caused by sudden impacts under low tire pressure conditions. ASB rims have a unique hook bead at the top of the rim profile that cradles the tire as it compresses under load, protecting the tube and preventing a ride-ending pinch flat. Go ahead and push it! The ALEXRIMS ASB design has you protected.

INNER TECHNOLOGY

**WELDED JOINT**

A well balanced wheel is the difference between a good wheel and a great wheel. ALEXRIMS Welded Joint rims provide a balanced feel so that every stroke of the pedals is transferred to the road or trail. In fact we think that a balanced wheel is so important that we build over 24 High Quality welded joint rims.

**SLEEVE JOINT**

Sleeve Joints provide more surface contact with a rim's inner wall for a more secure rim than pin joints but with the same lightweight properties.

**ROLLING PIN JOINT**

Wide rims for Fatbike and other speciality applications have unique cornering loads imposed on them. Lateral forces can cause one side of a rim to deflect more than the other. Rolling Pin technology adds internal structure to wide rims by embedding four pins (vs only two) to maintain structural integrity across the entire rim, not just at the edges.

**QUATTRO PIN JOINT**

Quattro Tec further increases the strength of Pin Joints by adding a second set of pins embedded in the bead hook profile to create a more torsionally rigid structure. The resultant bead hook profile not only strengthens the entire rim but also improves the tire/rim interface to reduce low pressure roll off.

MATERIAL TECHNOLOGY

**SSL (SCANDIUM SUPER LIGHT)**

Scandium Super Light is a space age material developed in our hi-tech 3C division. SSL is stronger, lighter & more rigid than any other alloy rim material.

**6A11**

Alex's 6A11 material is 1.2 times stronger than traditional 6061 series aluminum rims.

SURFACE TECHNOLOGY

**CSW (CNC SIDEWALLS)**

ALEX CSW technology is a precision CNC machined smooth sidewall to provide ultimate braking efficiency. CSW equipped rims are on our top range of products.

**GSW (GROUND SIDEWALLS)**

Precision ground sidewalls eliminate surface imperfections, add value and improve brake efficiency.

**CP (CHROME PLATED)**

Show chrome looks great and is long lasting. And is the choice of Pro BMX around the world.

**ASE (ALUMINUM SINGLE EYELETS)**

Aluminum Eyelets reduce stress on the rim, are lighter and offer better vibration absorption than stainless steel. ASE eyelets are standard equipment on our top level rims.

**SSE (STAINLESS SINGLE EYELETS)**

First developed by Alex in 1995, SSE improves seating of the nipple head for a better built wheel.

**SDE (STAINLESS DOUBLE EYELETS)**

SDE was developed by ALEX back in 2000. SDE improves seating of the nipple head for a better built wheel.

**EQUALIZER (RIM TECHNOLOGY)**

By utilizing 0.5mm off center spoke drilling from the hub centerline our Equalizer technology allow for the use of equally tensioned spokes on both sides of the wheel. Equal length spokes at equal tension make for a super strong wheel that is perfectly balanced from side to side.

**TRS (TUBELESS READY SYSTEM)**

Many of our rims offer our TRS (Tubeless Ready System) technology. Simply install any tubeless compatible tire, rim strip, valve and sealant system for a complete tubeless solution.



PRODD



DUCTS

RA30

Pin Joint | Black, Silver
Option: CSW

700C | 622x14 | 545g
650C | 571x14 | 490g

Origin: 

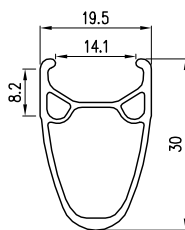

R450

Pin Joint | Black, Silver
Option: CSW

700C | 622x14 | 496g
650C | 571x14 | 468g
20"X1-1/8 | 450x14 | 356g

Origin:  

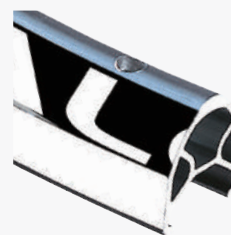
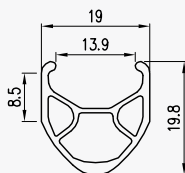

AT470

Pin Joint | Black
CSW | TRS

700C | 622x17 | 475g

Origin:  

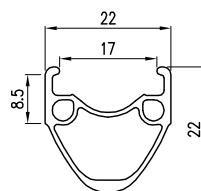

NEW

AT505

Pin Joint | Black
CSW | TRS

700C | 622x19 | 505g

Origin:  

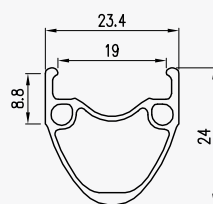

GV24P

Pin Joint | Black
CSW | TRS

700C | 622x21 | 508g

Origin:  

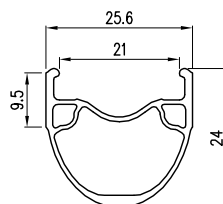

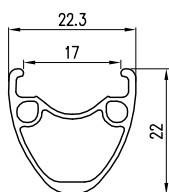

ATD470

Pin Joint | Black
TRS

700C | 622x17 | 460g

Origin:

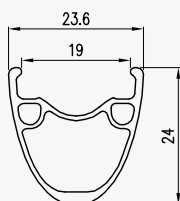

ATD500

Pin Joint | Black
TRS

700C | 622x19 | 500g

Origin:

NEW

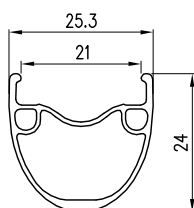

GD24P

Pin Joint | Black
TRS

700C | 622x21 | 500g
24" | 507x21 | 406g

Origin:

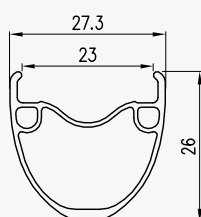

GX26P

Pin Joint | Black
TRS

700C | 622x23 | 545g
650B | 584x23 | 515g

Origin:

NEW



NEW

DP30

Pin Joint | Black
TRS | Option: SSE

29" | 622x30 | 605g
650B | 584x30 | 575g

Origin: 

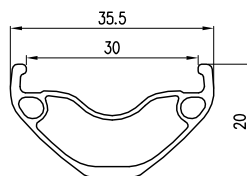

DP27

Pin Joint | Black
TRS | Option: SSE

29" | 622x27 | 542g
650B | 584x27 | 508g
26" | 559x27 | 490g

Origin: 

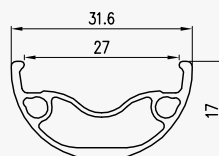

DP25

Pin Joint | Black
TRS | Option: SSE

29" | 622x25 | 510g
650B | 584x25 | 480g
26" | 559x25 | 460g
24" | 507x25 | 420g
20" | 406x25 | 330g

Origin: 

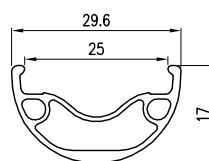

DP23

Pin Joint | Black
TRS | Option: SSE

29" | 662x23 | 500g
650B | 584x23 | 467g
26" | 559x23 | 445g
24" | 507x23 | 415g

Origin: 

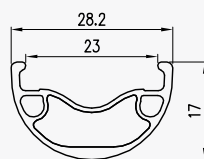

DP21

Pin Joint | Black
TRS | Option: SSE

29" | 622x21 | 490g
650B | 584x21 | 460g
26" | 559x21 | 445g
24" | 507x21 | 390g
20" | 406x21 | 310g

Origin: 

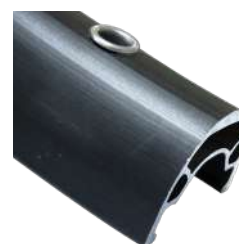
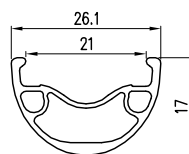

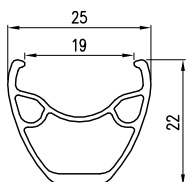

XD-ELITE

Pin Joint | Black
Option: SSE

29" | 622x19 | 510g
650B | 584x19 | 480g
26" | 559x19 | 450g

Origin:

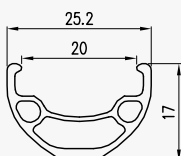

MD19

Pin Joint | Black
Option: SSE

29" | 622x20 | 490g
650B | 584x20 | 470g
26" | 559x20 | 440g
24" | 507x20 | 390g
20" | 406x20 | 310g

Origin:

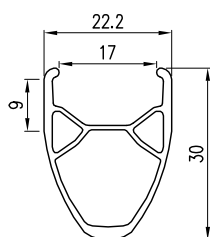

G6000

Pin Joint | Black
Option: CSW

29" | 622x17 | 698g
26" | 559x17 | 629g

Origin:

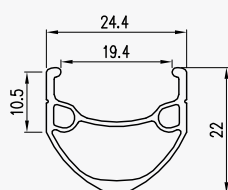

X2200

Pin Joint | Black
Indicator
Option: CSW

29" | 622x19 | 510g
650B | 584x19 | 485g
26" | 559x19 | 460g

Origin:

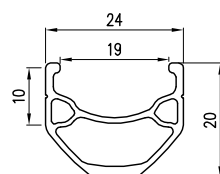

X2000

Pin Joint | Black | Silver
Indicator
Option: CSW | SSE

29" | 622x19 | 554g
650B | 584x19 | 525g
26" | 559x19 | 500g

Origin:

X2800

Pin Joint | Black
 TRS | Option: CSW | SSE

29" | 622x19 | 550g
 650B | 584x19 | 505g
 26" | 559x19 | 490g

Origin: 

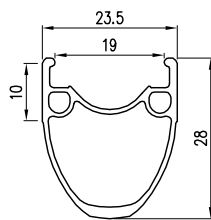

XD2800

Pin Joint | Black
 TRS | Option: SSE

29" | 622x19 | 540g
 650B | 584x19 | 505g

Origin: 

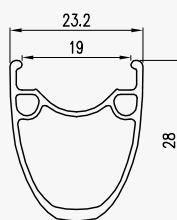

DH19

Pin Joint | Black
 Option: CSW | SSE

29" | 622x18 | 580g
 650B | 584x18 | 575g
 26" | 559x18 | 520g
 20" | 406x18 | 385g

Origin: 

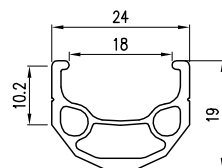

EV23

Pin Joint | Black
 TRS | Indicator | Option: CSW, SSE

29" | 622x23 | 550g
 650B | 584x23 | 520g
 26" | 559x23 | 500g

Origin: 

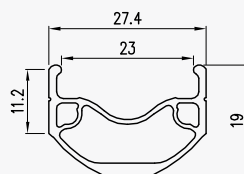

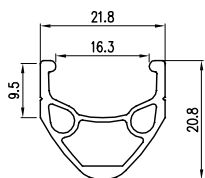

DA16

Pin Joint | Black, Silver
Indicator | Option: CSW

- 29" | 622x16 | 550g
- 26" | 559x16 | 503g
- 24"X1 3/8 | 540x16 | 480g
- 24" | 507x16 | 450g
- 20"X1 3/8 | 451x16 | 400g
- 20" | 406x16 | 380g
- 18" | 355x16 | 310g
- 16" | 305x16 | 260g

Origin:

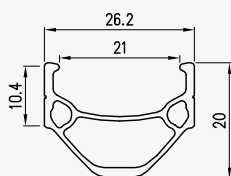

X1700

Pin Joint | Silver, Black
Indicator | Option: CSW | SSE

- 29" | 622x21 | 510g
- 650B | 584x21 | 480g
- 26" | 559x21 | 460g
- 24" | 507x21 | 445g
- 20" | 406x21 | 355g

Origin:

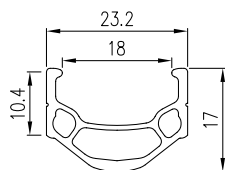

ACE17

Pin Joint | Silver, Black
Indicator | Option: CSW | SSE

- 29" | 622x18 | 530g
- 650B | 584x18 | 505g
- 26" | 559x18 | 480g
- 24" | 507x18 | 420g
- 20" | 406x18 | 330g

Origin:

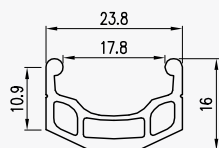
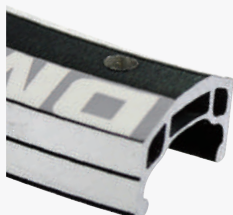

DM18

Pin Joint | Black
Option: CSW | SSE | Indicator

- 29" | 622x18 | 586g
- 650B | 584x18 | 550g
- 26" | 559x18 | 530g
- 24" | 507x18 | 486g
- 20" | 406x18 | 380g

Origin:

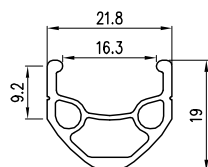
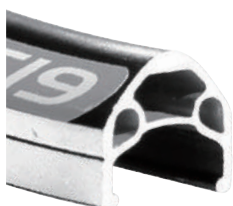

DC19

Pin Joint | Black, Silver
Indicator | Option: CSW

- 29" | 622x16 | 562g
- 26" | 559x16 | 509g

Origin:

MD35

Pin Joint | Black
TRS

29" | 622x34 | 545g
650B | 584x34 | 525g
26" | 559x34 | 490g

Origin:  

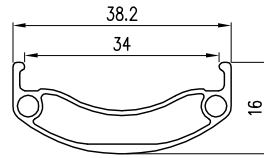



DM24

Pin Joint | Black, Silver
Indicator | Option: CSW | SSE

- 29" | 622x24 | 725g
- 26" | 559x24 | 665g
- 24" | 507x24 | 610g
- 20" | 406x24 | 480g

Origin: 

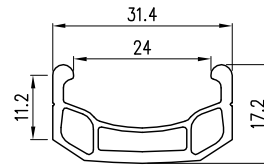

MUS30

Pin Joint | Black

- 26" | 559x24 | 520g
- 24" | 507x24 | 475g
- 20" | 406x24 | 365g

Origin: 

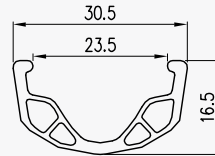

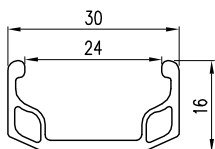

Y303

Pin Joint | Black, Silver
Option: GSW

- 26" | 559x24
- 24" | 507x24
- 20" | 406x24
- 18" | 355x24
- 16" | 305x24

Origin:

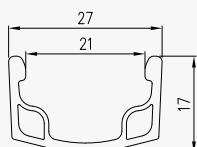

C303

Pin Joint | Black, Silver
Option: GSW

- 27"x1 1/4 | 630x21
- 26"x1 3/8 | 597x21
- 24"x1 3/8 | 540x21
- 24" | 507x21
- 20" | 406x21

Origin:

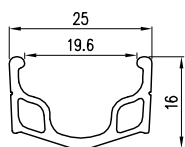

C1000

Pin Joint | Silver, Black
Indicator | Option: CSW

- 26" | 559x20
- 24" | 507x20
- 22" | 456x20
- 20" | 406x20
- 18" | 355x20
- 16" | 305x20
- 14" | 251x20
- 12" | 203x20

Origin:

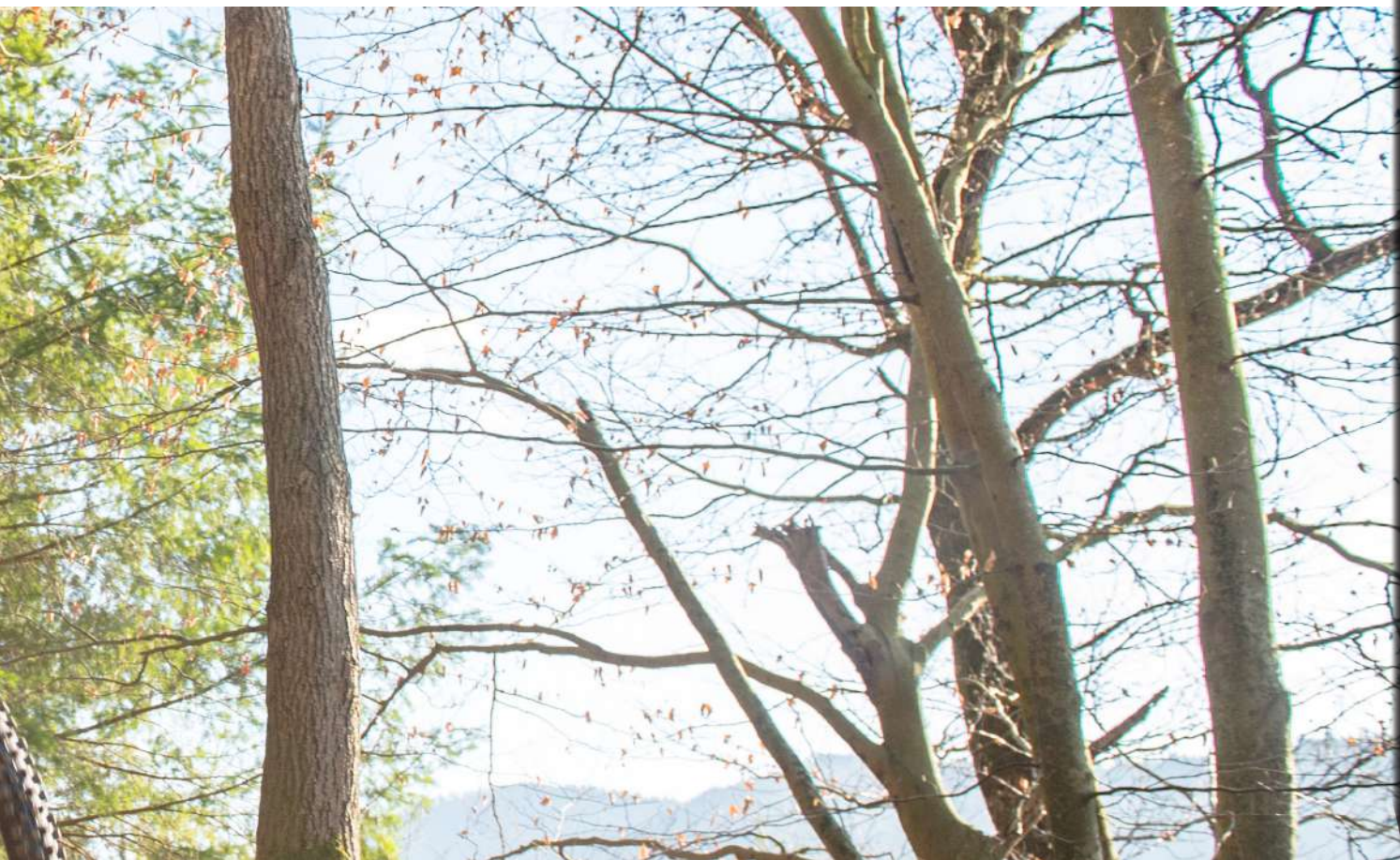

ZUMA1.0

Pin Joint | Silver, Black



650B | 584x27
 26" | 559x27
 24" | 507x27

Origin:

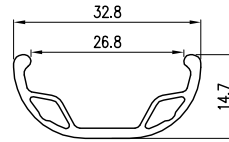

ZUMA3.0

Pin Joint | Silver, Black



26" | 559x26
 24" | 507x26
 18" | 355x26

Origin:

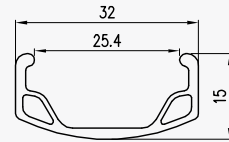

AP18

Pin Joint | Silver, Black
 Option: CSW



700C | 622x18
 27"X1 1/4 | 630x18
 26" | 559x18
 20" | 406x18

Origin:

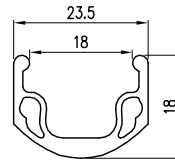

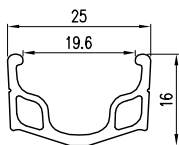

Z1000

Pin Joint | Silver, Black
Option: CSW

- 29" | 622x20
- 650B | 584x20
- 26" | 559x20
- 24" | 507x20
- 22" | 456x20
- 20" | 406x20
- 18" | 355x20
- 16" | 305x20
- 14" | 251x20
- 12" | 203x20

Origin:

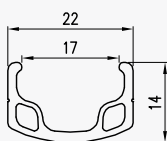

C2000

Pin Joint | Silver, Black
Option: CSW

- 16" | 305x17
- 14" | 254x17
- 12" | 203x17

Origin:

NEW



DP23

Pin Joint | Black
TRS | Option: SSE

29" | 622x23 | 500g
650B | 584x23 | 467g
26" | 559x23 | 445g

Origin:  

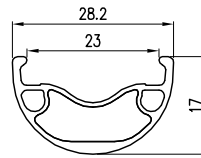

DM24

Pin Joint | Black
Indicator | Option: CSW

29" | 622x24 | 725g
650B | 584x24 | 670g
24" | 507x24 | 610g
20" | 406x24 | 480g

Origin: 

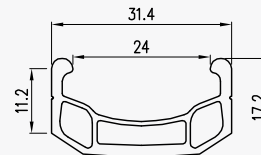

EV23

Pin Joint | Black
TRS | Indicator
Option: CSW, SSE

700C | 622x23 | 595g
26" | 559x23 | 540g

Origin: 

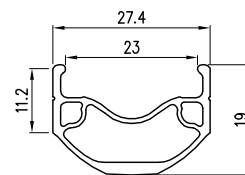

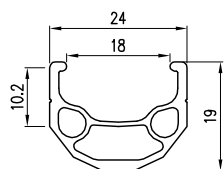

DH19

Pin Joint | Black
Indicator | Option: CSW

29" | 622x18 | 580g
26" | 559x18 | 520g

Origin:

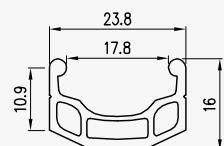
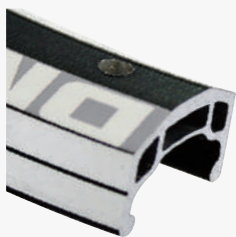

DM18

Pin Joint | Black
Indicator | Option: CSW

29" | 622x18 | 600g
650B | 584x18 | 530g
26" | 559x18 | 520g

Origin:





ALEXRIMS

FOR THE WAY YOU RIDE

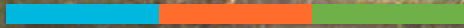



亞獵士科技股份有限公司

ALEX GLOBAL TECHNOLOGY INC.
台南市山上區明和里北勢洲21-2號
No.21-2, Beishizhou, Minghe Vil.,
Shanshang Dist., Tainan City 743,
Taiwan

電話：+886-6-5782151

傳真：+886-6-5782394

E-MAIL：alexirms@alexirms.com.tw

WEB：www.alexirms.com

益昌鋁製品（太倉）有限公司

XYZ ALUMINIUM PRODUCTS
(TAI CANG) CO., LTD.

江蘇省太倉市沙溪鎮岳王臺北路2號
No.2 Tai-Pei Road, Yue-Wang District,
Sha-Xi Town, Tai-Cang City, Jiang-Su
Province, China

電話：+86-512-5345 6636 53458348

傳真：+86-512-5345 8322

E-mail: alextc53456636@163.com

大造熊有限公司

DA CHAO SHONG CO., LTD.

柬埔寨柴楨省巴域市國道一號大成巴域
經濟特區+ (大造熊公司)

Tai Seng Bavet Special Economic
Zone, National Road. 1, Bavet City,
Svay Rieng Province, Cambodia
Da Chao Shong Co., Ltd.

電話：+855-44-712265

E-MAIL: dachaoshong@gmail.com

大造熊科技股份有限公司

BEAR PAWLS, INC.

428-72台中市大雅區鳳鳴路6-1號

1F., NO.6-1, Fengming Rd., Daya Dist.,
Taichung City 42872, Taiwan (R.O.C)

電話：+886-4-25606996

傳真：+886-4-25606886

E-MAIL: bearpawls@bearpawls.com.tw

WEB: www.bearpawls.com

WWW.ALEXRIMS.COM